

SIGMAQ

for QUATTRO-G3D

Dual frequency satellite-based four-antenna system SIGMAQ is a receiver based on our TRIUMPH Technology implemented in our TRIUMPH Chip. For the first time in the GNSS history we offer up to 100 Hz RTK. SigmaQ is a powerful receiver for high accuracy applications. The dual frequency code and carrier data from four antennas are processed to determine the three orientation angles and three dimensional position up to 100 times per second.

216 channels of single or dual frequency GPS, Galileo and GLONASS in a small attractive, sturdy, and watertight box, which contains Quattro-G3D board.

The on-board power supply on SIGMAQ receiver accepts any voltage from +10 to +30 volts and delivers clean filtered voltage where needed. This eliminates the risk of power contamination (ripples) that can be created when clean power is generated elsewhere and delivered to the board via cables. SIGMAQ receiver also includes TriPad (two LEDs, ON/OFF and function button), GSM/CDMA2000 module, and UHF modem.

In addition, the receiver comes with large amount of flash for data storage. The CAN interface in SIGMAQ receiver is provided complete with all associated hardware and firmware, not just the CAN bus. The same is true with all the serial RS232/RS422 ports in our receiver. Simply stated, additional functions are not needed to incorporate any of our SIGMAQ Receiver in most applications.

In addition to timing strobe and event marker, the SIGMAQ receiver includes the option of complete IRIG timing system.

Standard Configuration

- Memory 0 MB
- GPS L1/L2
- GLONASS L1/L2
- Galileo E1
- RAIM
- TriPad Interface
- RS232 Serial Port (460.8 kbps)
- 4x External GNSS Antenna TNC Female connector
- Rechargeable Li-Ion Batteries

Optional Feature

- Update Rate 1 Hz, 5Hz, 10Hz, 20Hz, 50Hz & 100Hz
- RTK Rate 1 Hz, 5Hz, 10Hz, 20Hz, 50Hz & 100Hz
- Data Recording up to 2048MB
- Multi-Base Code Differential Rover
- Code Differential Base
- Advanced Multipath Reduction
- In-Band Interference Rejection
- Two Event Markers
- Two 1 PPS timing strobes
- CAN 2.0 port
- External Reference Frequency input
- Up to 2 high Speed (460.8 kbps) RS232 Serial Ports
- High speed RS422 serial port (up to 460.8 kbps)
- USB port
- Ethernet
- Bluetooth® Interface
- Internal UHF Modem
- Internal GSM/GPRS Module
- Internal CDMA2000 Module
- External UHF, GSM/CDMA2000, Bluetooth Antenna Connectors
- KFK WAAS/EGNOS (SBAS)
- 2x External Power Inputs
- Mounting Bracket

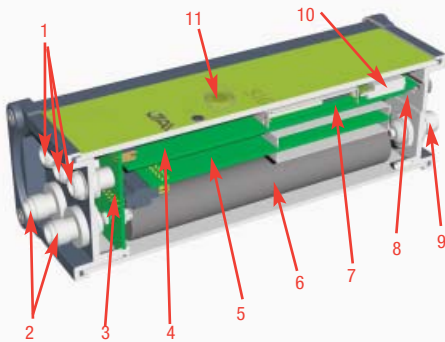

1. Communication and Power Ports
2. External GNSS Antenna Connectors
3. GNSS Interconnect Board
4. GNSS Power and Communication Board with on-board SIM-card
5. GNSS Receiver with on-board Memory
6. Rechargeable Li-Ion Battery Pack
7. UHF Modem
8. SIM Card Holder
9. External UHF, GSM/CDMA2000, Bluetooth Antenna Connectors
10. GSM/CDMA2000 Modem
11. On/Off Button

Specifications are subject to change without notice.

Description

Total 216 channels: all-in-view (GPS L1/L2, Galileo E1, GLONASS L1/L2, SBAS) integrated receiver, rugged aluminum housing complete with TriPad interface

Tracking Specification

Tracking Channels	1x (GPS L1/L2, Galileo E1, GLONASS L1/L2, SBAS)+3x (GPS L1/L2, Galileo E1, SBAS)
Signals Tracked	L1/L2 C/A and P Code & Carrier

Performance Specifications

Autonomous Static, Fast Static Accuracy	<2 m Horizontal: 0.3 cm + 0.5 ppm * base_line_length Vertical: 0.5 cm + 0.5 ppm * base_line_length
Kinematic Accuracy	Horizontal: 1 cm + 1 ppm * base_line_length Vertical: 1.5 cm + 1.5 ppm * base_line_length
RTK (OTF) Accuracy	Horizontal: 1 cm + 1 ppm * base_line_length Vertical: 1.5 cm + 1.5 ppm * base_line_length
DGPS Accuracy	< 0.25 m Post Processing < 0.5 m Real Time
Real time attitude accuracy	Heading ~ 0.004/L [rad] RMS, where L is the antenna separation in [m]
Cold Start	<35 seconds
Warm Start	<5 seconds
Reacquisition	<1 second

Power Specification

External power input	2, 1 - primary, 1 - secondary port(s)
Input Voltage	+10 to +30 volts

GNSS Antenna Specifications

GNSS Antenna	External
--------------	----------

Radio Specifications

GSM/GPRS Module	Internal GSM/GPRS quad-band module, GPRS Class 10
UHF Radio Modem	Internal 360-470 MHz radio transceiver, up to 38.4 kbps
Base Power Output	1 Watt

I/O

Battery	Two internal Li-Ion batteries (7.4 V, 4.4 Ah each) with internal charger
External Power port	2 ports
Communication Ports	2x serial (RS232) up to 460.8 kbps High speed RS422 serial port (up to 460.8 Kbps) High speed USB 2.0 device port (480 Mbps) Full-duplex 10BASE-T/100BASE-TX Ethernet port Bluetooth V1.2 Class 2 supporting SPP Slave Profile CAN
Other I/O Signals	External Reference Frequency input 2x 1 PPS synchronized 2x Event Marker IRIG
Status Indicator	Two LEDs, two function keys (TriPad)

Memory & Recording

Internal Memory	Up to 2048MB of onboard non-removable memory for data storage
Raw Data Recording	Up to 100 times per second (100Hz)
Data Type	Code and Carrier from GPS L1/L2/Galileo E1/GLONASS L1/L2

Data Output

Real time data outputs	RTCM SC104 versions 2.x and 3.x Input/Output
ASCII Output	NMEA 0183 versions 2.x and 3.0 Output
Output Rate	Code and Carrier

Environmental Specifications

Enclosure	Aluminum extrusion, waterproof IP 67
Operating Temperature	-30 ° C to +55° C (with batteries)/-40° C to +80° C (without batteries)
Storage Temperature	-20° C to +45° C (with batteries) /-45° C to +85° C (without batteries)
Humidity	100% condensing
Shock	Survives a 1 m drop onto hard surface
Dimensions	W: 132 mm x H: 61 mm x D: 190 mm
Weight	1330 g

